

Questions on Lesson 4.3?

If not, get ready to start lesson

4.4!

SM2 Ch4 Student Text.pdf - Adobe Reader
File Edit View Window Help
289 (33 of 76) 150%
Tools Sian Comment
View or add comments

2. \overline{CD} bisects $\angle C$. Solve for DB .

$\frac{24}{30} = \frac{8}{x}$

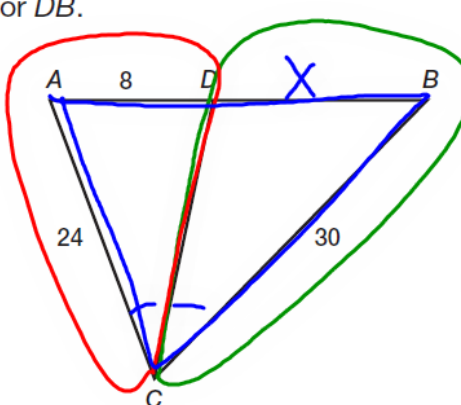

$**$

~~$\frac{24}{8} = \frac{30}{x}$~~

$8 \cdot 30 = 24x$

$\frac{240}{24} = \frac{24x}{24}$

$10 = x$

SM2 Ch4 Student Text.pdf - Adobe Reader
File Edit View Window Help
289 (33 of 76) 150% Tools Sign Comment
View or add comments

3. \overline{CD} bisects $\angle C$. Solve for AC.

$\frac{9}{11} = \frac{x}{22}$

$\frac{11}{9} = \frac{22}{x}$

$\frac{x}{9} = \frac{22}{11}$

~~$\frac{9}{x} = \frac{11}{22}$~~

$9 \cdot 22 = 11x$
 $198 = 11x$
 $\frac{198}{11} = \frac{11x}{11}$
 $18 = x$

SM2 Ch4 Student Text.pdf - Adobe Reader
 File Edit View Window Help
 290 (34 of 76) 150%
 Tools Sign Comment
 View or add comments

4. \overline{AD} bisects $\angle A$. $AC + AB = 36$. Solve for AC and AB.

$$\frac{x}{7} = \frac{36-x}{14}$$

$$14x = 7(36-x)$$

$$14x = 252 - 7x$$

$$+7x \quad +7x$$

$$\frac{21x}{21} = \frac{252}{21}$$

$$\boxed{x = 12}$$

$y = 36 - x = 24$

$x = 12$

$$\begin{aligned} x + y &= 36 \\ -x & \\ \hline y &= 36 - x \end{aligned}$$

$$\begin{aligned} 7 \cdot 36 & \\ 7 \cdot 30 &= 210 \\ 7 \cdot 6 &= 42 \end{aligned}$$

4.4

Geometric Mean
More Similar Triangles

PG.305 IN YOUR BOOK

A bridge is needed to cross over a canyon. The dotted line segment connecting points S and R represents the bridge. The distance from point P to point S is 45 yards. The distance from point Q to point S is 130 feet. How long is the bridge?

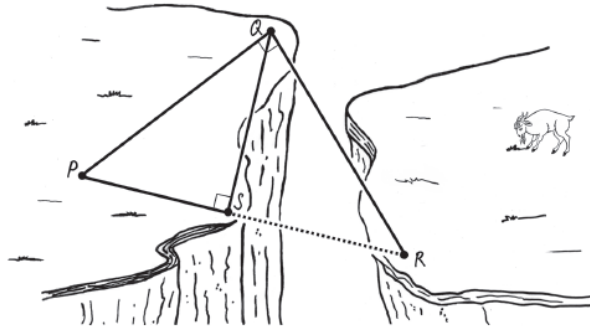

To determine the length of the bridge, you must first explore what happens when an altitude is drawn to the hypotenuse of a right triangle.

When an altitude is drawn to the hypotenuse of a right triangle, it forms two smaller triangles. All three triangles have a special relationship.

1. Construct an altitude to the hypotenuse in the right triangle ABC . Label the altitude CD .

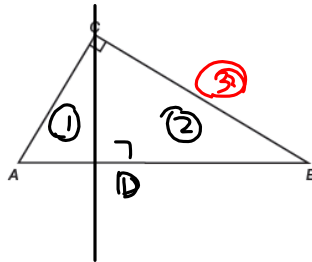

We're going to explore these relationships in several triangles first. Then we can answer the question at the beginning of this problem.



WORK ON #2-5 ON PG.305-6 WITH YOUR GROUP

2. Name all right triangles in the figure.
3. Trace each of the triangles on separate pieces of paper and label all the vertices on each triangle. Cut out each triangle. Label the vertex of each triangle. Arrange the triangles so that all of the triangles have the same orientation. The hypotenuse, the shortest leg, and the longest leg should all be in corresponding positions. You may have to flip triangles over to do this.

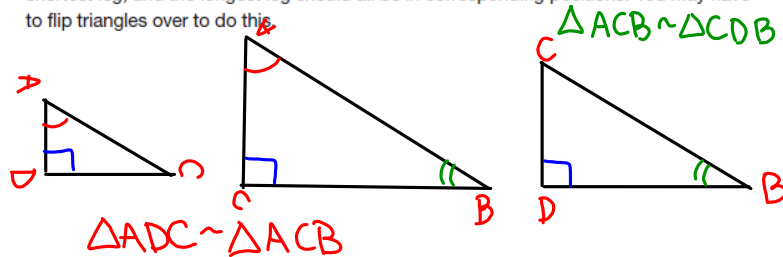

4. Name each pair of triangles that are similar. Explain how you know that each pair of triangles are similar.

$\Delta ADC \sim \Delta ACB$ $\Delta ACB \sim \Delta CDB$

so $\Delta ADC \sim \Delta CDB$ (transitive prop.)

5. Write the corresponding sides of each pair of triangles as proportions.

$\Delta ADC \sim \Delta CDB$ $\Delta ADC \sim \Delta ACB$ $\Delta ACB \sim \Delta CDB$

$$\frac{AD}{CD} = \frac{AC}{CB} = \frac{CD}{DB}$$

$$\frac{AD}{AC} = \frac{DC}{CB} = \frac{AC}{AB}$$

$$\frac{AC}{CD} = \frac{CB}{DB} = \frac{AB}{CB}$$

PG.306 IN YOUR BOOK

The Right Triangle/Altitude Similarity Theorem states: "If an altitude is drawn to the hypotenuse of a right triangle, then the two triangles formed are similar to the original triangle and to each other."

PG.307 IN YOUR BOOK

When an altitude of a right triangle is constructed from the right angle to the hypotenuse, three similar right triangles are created. This altitude is a *geometric mean*.

The *geometric mean* of two positive numbers a and b is the positive number x such that $\frac{a}{x} = \frac{x}{b}$.

Two theorems are associated with the altitude to the hypotenuse of a right triangle.

The *Right Triangle Altitude/Hypotenuse Theorem* states: "The measure of the altitude drawn from the vertex of the right angle of a right triangle to its hypotenuse is the geometric mean between the measures of the two segments of the hypotenuse."

The *Right Triangle Altitude/Leg Theorem* states: "If the altitude is drawn to the hypotenuse of a right triangle, each leg of the right triangle is the geometric mean of the hypotenuse and the segment of the hypotenuse adjacent to the leg."

1. Use the diagram from Problem 1 to answer each question.

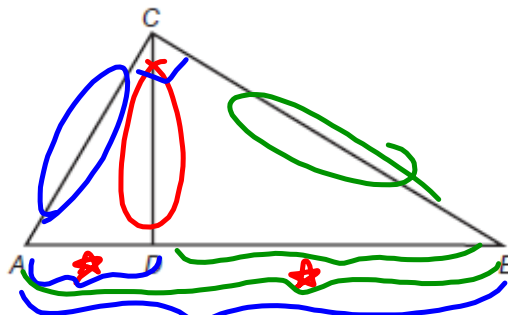

- a. Write a proportion to demonstrate the Right Triangle Altitude/Hypotenuse Theorem?

$$\frac{AD}{CD} = \frac{CD}{DB} \quad \text{OR} \quad \frac{CD}{AD} = \frac{DB}{CD}$$

- b. Write a proportion to demonstrate the Right Triangle Altitude/Leg Theorem?

$$\frac{AB}{AC} = \frac{AC}{AD} \quad \text{AND} \quad \frac{AB}{CB} = \frac{CB}{DB}$$

MAKE SURE YOU FINISH PGS.308-310

NOT IN YOUR BOOK, BUT LIKE PROBLEMS ON PAGES 308-310

Solve for x.

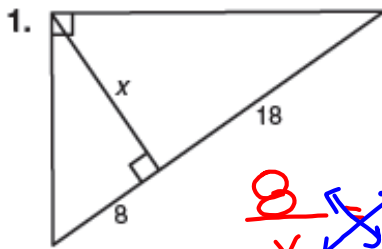

$$\frac{8}{x} = \frac{x}{18}$$

$$\sqrt{x^2} = \sqrt{144}$$

$$x = 12$$

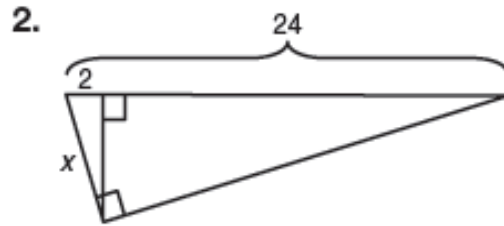

$$\frac{24}{x} = \frac{x}{2}$$

$$\sqrt{x^2} = \sqrt{48}$$

$$x = \sqrt{4} \cdot \sqrt{12}$$

$$x = 2\sqrt{12}$$

$$x = 2\sqrt{4} \sqrt{3}$$

$$x = 4\sqrt{3}$$

4. The geometric mean of two numbers is 20. One of the numbers is 50. What is the other number

$$\frac{50}{20} = \frac{20}{x}$$

$$\frac{50x}{50} = \frac{400}{50}$$

$$x = 8$$

Solve for a, b, and c.

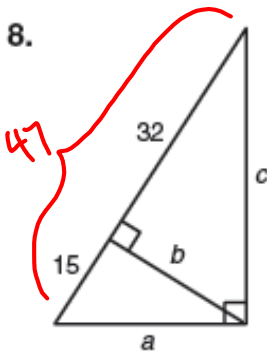

$$\frac{15}{b} = \frac{b}{32}$$

$$\frac{15}{a} = \frac{a}{47}$$

$$\frac{32}{c} = \frac{c}{47}$$

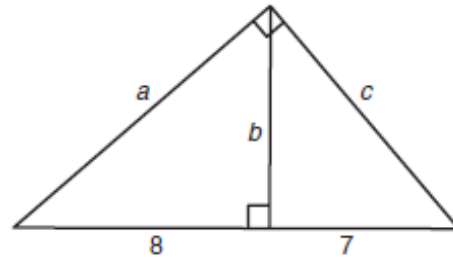

10. You are standing 15 feet from a tree. Your line of sight to the top of the tree and to the bottom of the diagram. The distance between your line of sight and tree.

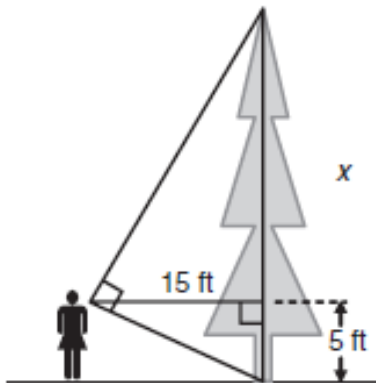

Homework

Finish 4.4